

MOD-102-ST

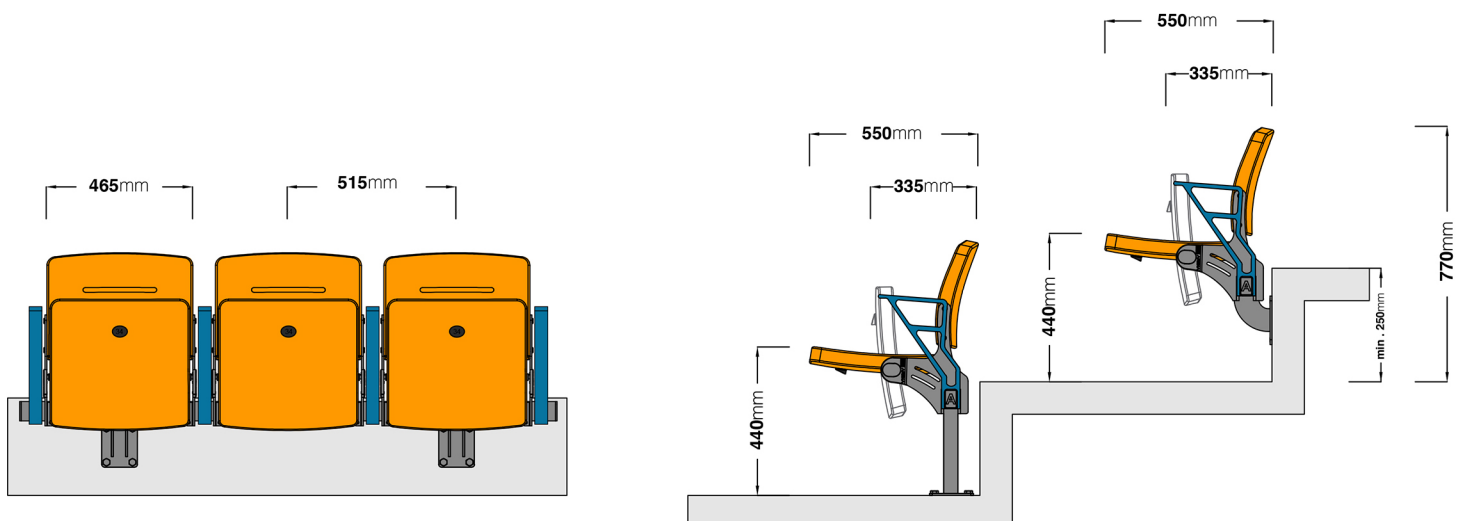

- Mod-102-ST stadium seat is mounted with sleeper (rail system). The sleepers are mounted at the height of the riser and optionally on the riser (step front) or on the floor. Thanks to the sleeper system, the seats can be fixed easily and quickly. Thanks to the sleeper system, the seats can be fixed easily and quickly. Thanks to this system, it is possible to adapt the space to the desired capacity, to adjust the distance between the seats or to make possible product and layout arrangements easily. Thanks to its center of gravity system, Mod-102-ST stadium seat is maintenance-free throughout its lifetime.
- Cast polyurethane sponge is used in the seat and back front of the seats and there is a metal frame inside. The polyurethane and artificial leathers used are manufactured with non-combustibility additives. 4 mm lamination is applied to the furnishings used in the Mod-102-ST stadium seat. The furnishing area on the back front allows logo and advertising applications. The furnishing used in the seats is manufactured with additives resistant to UV, abrasion, chlorine and combustion. Mod-102-ST stadium seat has PP injection armrest. Armrests can optionally be manufactured in common or as two pieces for each stadium seat. Armrests are connected to the sleeper system. The numbering area under the seat front and the optional sleeper row number allow users to find their places more easily and quickly. Thanks to the thin structure of the seat, it is possible to relieve the circulation on the steps and increase the capacity.



TECHNICAL SPECIFICATIONS:

- The rail system, which seats are firmly attached to, provides the opportunity slide the seats to right and left, and the seats can be easily replaced with new ones in the future.
- Artificial leathers used in furnishings are manufactured with additives that provide high resistance against salt, UV rays, fire and chlorine.
- Compliance with the EN FMV SS 302 with non-combustibility additive.
- The metal parts of the seats are designed and manufactured from 6 mm one-piece sheet metal without welding, by laser cutting and bending in press molds.
- 50+- 10% density polyurethane filling sponge on metal frame.
- Corrosion resistant in accordance with EN ISO 9227.
- The highest resistance to hooliganism in accordance with EN ISO 12727-4.
- Artificial leathers used in furnishings are covered with non-combustible 4 mm lamination.
- Tip-up mechanism that works with the center of gravity system.
- The rail system provides the possibility of mounting on the floor or on the riser.
- Backrest suitable for logo and advertisement embroidery application.
- Seat numbering area under the seat is available optionally.
- PP armrests on the seats.

ACCESSORIES:

- Backrest logo application.
- Seat number tag.
- Mechanism covers.
- Rail system row tag.



Quick Acces

