

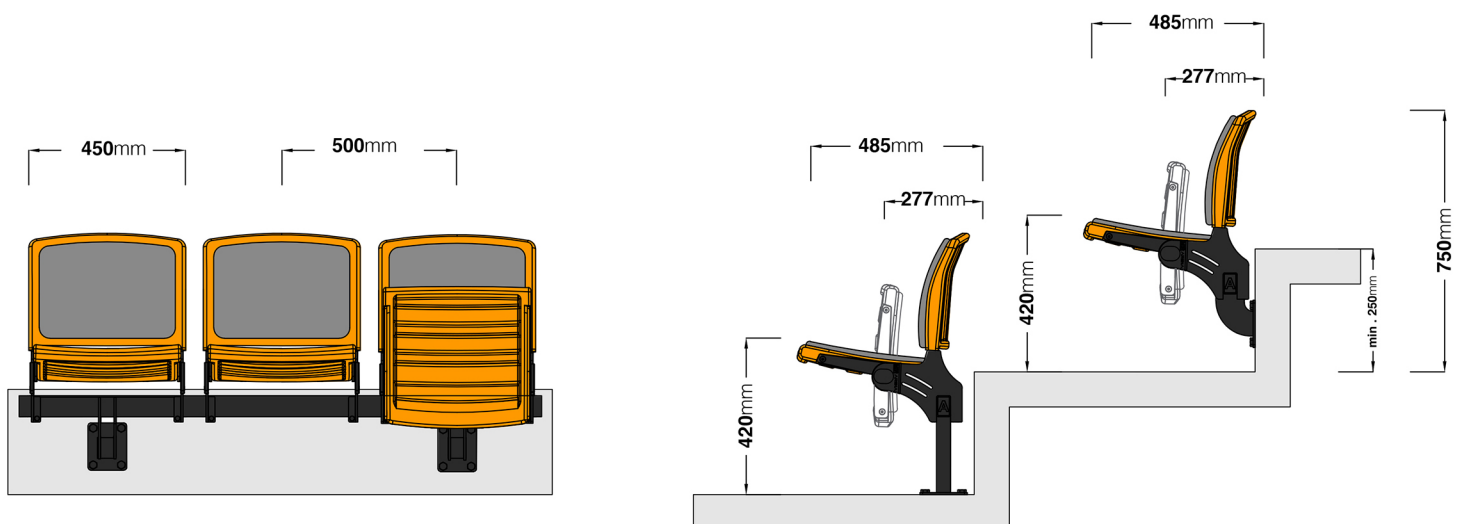

- Fly-102-D stadium seat is mounted with sleeper (rail system). The sleepers are mounted at the height of the riser and optionally on the riser (step front) or on the floor. Thanks to the sleeper system, the seats can be fixed easily and quickly. Thanks to the sleeper system, the seats can be fixed easily and quickly. Thanks to this system, it is possible to adapt the space to the desired capacity, to adjust the distance between the seats or to make possible product and layout arrangements easily. Thanks to its center of gravity system, Fly-104 stadium seat is maintenance-free throughout its lifetime.

- The plastic seat and back used in the seats are manufactured as PP or PE by blowing method. Thanks to the internal metal construction in the seat front, the durability of the product has been maximized. Fly-102-D stadium seat has furnished fronts integrated into the back and seat parts of the seat. The furnishing area on the back front allows logo and advertising applications. The furnishing used in the seats is manufactured with additives resistant to UV, abrasion, chlorine and combustion. The numbering area under the seat front allows users to find their places more easily and quickly. Thanks to the thin structure of the seat, it is possible to relieve the circulation on the steps and increase the capacity.



## TECHNICAL SPECIFICATIONS:

- Compliance with the EN ISO 11925-2 and 13501-1/E class with non-combustibility additive.
- The metal parts of the seats are designed and manufactured from 6 mm one-piece sheet metal without welding, by laser cutting and bending in press molds.
- The rail system, which seats are firmly attached to, provides the opportunity slide the seats to right and left, and the seats can be easily replaced with new ones in the future.
- Seat and back fonts have leather furnishings on sponge. Suitable for logo and advertisement embroidery application.
- Produced from PE or PP.
- UV added in accordance with EN ISO 4892-2.
- Corrosion resistant in accordance with EN ISO 9227.
- The highest resistance to hooliganism in accordance with EN ISO 13200-4.
- Tip-up mechanism that works with the center of gravity system.
- The rail system provides the possibility of mounting on the floor or on the riser.
- The plastic weight of the seats is 3.250 gr and the total is 9.540 gr.
- Logo and advertising area on the backrest.
- Seat numbering area under the seatrest.

## ACCESSORIES:

- Backrest logo application.
- Seat number tag.
- Mechanism covers.
- Rail system row tag.



Quick Acces